

Freightliner Business Class M2

Cab and Chassis Vocational Reference Guide

Section

1

General Information

Final Version

Freightliner Business Class M2

Cab and Chassis Vocational Reference Guide

General Information



This manual is a source of basic information for body and equipment manufacturers, and dealers who install their products on Freightliner Medium and Heavy Duty truck chassis. Information on brake systems, electrical circuits, and chassis layout is included. This information is not intended for use by anyone who does not have substantial technical expertise in the design and manufacture of motor vehicles and motor vehicle equipment.

The information in this manual is believed to be accurate to the best of our knowledge at the time this manual was approved for publication. The accuracy is not guaranteed. The information contained in the manual is general and nothing contained herein should be regarded as providing specific or comprehensive instructions for the completion of a particular vehicle, or as authorization by Freightliner Trucks of the assembly, modification, or alteration of any particular vehicle, whether delivered by Freightliner Trucks in complete or incomplete state of manufacture. Representations regarding the compliance of any Freightliner incomplete vehicle to any rule, regulation, or standard issued pursuant to the National Traffic and Motor Vehicle Safety Act or Canadian Motor Vehicle Safety Act is set forth only on the incomplete vehicle certificate accompanying each incomplete vehicle. Freightliner reserves the right to discontinue models or change specifications or designs at any time without notice and without incurring any obligation.

Note: Dimensions in parentheses are millimeters

Introduction

This Cab and Chassis Modification Guide covers the following Freightliner vehicles:

BUSINESS CLASS M2

Regulations such as those issued by the Federal Highway Administration or issued pursuant to the Occupational Safety and Health Act (OSHA), and/or state, provincial and local laws and regulations may require installation of additional equipment for the particular use intended for the vehicle. Nothing contained herein is to be construed as a representation that such equipment required for the particular use intended has been installed on the complete or incomplete vehicle.

If clarification regarding content of this publication or technical information is required, such as a DXF file for a specific VIN, please call the Customer Application Engineering Department listed at 503-745-4636.

If you choose to contact us by letter our address is:

**Freightliner Trucks
Customer Application Engineering
2477 Deerfield Dr.
Fort Mill, SC 29715**

As a vehicle manufacturer, Freightliner neither approves nor disapproves truck chassis modifications or equipment installations because Freightliner cannot control the manufacturing techniques of the various body/ equipment builders.

Freightliner Business Class M2 Cab and Chassis Vocational Reference Guide

General Information

A chassis cab manufactured by Freightliner Trucks is certified for compliance with the U.S. and Canadian Motor Vehicle Safety Standards as an incomplete vehicle which may be completed into a truck type vehicle. The vehicle certification is a requirement of the National Traffic and Motor Vehicle Safety Act (United States) and Canadian Motor Vehicle Safety Act (Canada).

This manual provides general instructions and suggestions for the installation of bodies and equipment on Freightliner Medium and Heavy Truck chassis as well as general guidelines for modifications to Freightliner Medium and Heavy Trucks. Following these suggestions will contribute substantially to the longevity of the vehicle. The suggestions published in this manual are general in nature and assume that the facility workshop and workers performing the tasks of installation or modification use accepted shop practices and techniques.

Freightliner does not assume any liability for damage(s) to persons or property caused by use of this publication. Modifications, alterations, and installations are the sole responsibility of those performing the work.

ENGINE EXHAUST EMISSION CONTROL INFORMATION

Title II of the Clean Air Act, as amended, requires vehicle manufacturers to supply the purchaser of a commercial vehicle with all the service and maintenance literature necessary to ensure the emission-related components function properly for the useful life period. The useful life period varies with fuel, vehicle type, and GVWR as defined by 40 CFR, Sections 86.094-2 and 86.096-2. In compliance with the provisions, the Driver's Manual and Maintenance Manual (workshop type) contain all the information required for the operation and maintenance of the factory-installed emission related components of your Freightliner Medium and Heavy Truck engine.

The Environmental Protection Agency has certified each engine, thereby confirming it meets exhaust emission standards for the new engines. To be certain the emission related components function over the useful operation as designed, regular maintenance is necessary for these components.

The required services and procedures are in the "Required Vehicle Service and Maintenance Work" section of the Driver's Manual.

Note: Dimensions in parentheses are millimeters

Emission, Noise and Safety

The Emission Control Warranty covers a period of 50,000 miles or 5 years, whichever occurs first, for all heavy duty gasoline engines and heavy duty diesel engines under 19,500 lbs. GVWR. For all other heavy duty diesel engines, this warranty period is 100,000 miles or 5 years, whichever occurs first.

The Emission Control Warranty does not cover repair or replacement of parts necessitated by the failure to use appropriate fuels and lubricants (listed in the "Lubricants and Fluids" section of the appropriate Engine Operations and Maintenance Manual), or the failure to properly maintain the emission related components. Maintenance must be performed at the intervals indicated in the "Maintenance Categories and Intervals" section of the Driver's Manual.

If engine settings are not adhered to at maintenance inspections, or if improper modifications are made on emission related components, excessive exhaust emissions and engine or drivetrain damage may result. It is the vehicle owner's responsibility to be certain that no unauthorized adjustments or modifications are made to their truck(s).

In addition, the Clean Air Act, as amended, prohibits any person engaged in the business of repairing, servicing, selling, leasing, or trading motor vehicles or motor vehicle engines, or who operates a fleet of motor vehicles, knowingly to remove or render inoperative any device or element of the design installed in a motor vehicle or a motor vehicle engine in compliance with the regulations under this Title following its sale and delivery to the ultimate purchaser.

The Emission Certification label location for each engine is shown on the chart on page 1-8 of this manual.

Freightliner Business Class M2

Cab and Chassis Vocational Reference Guide

General Information

Emission, Noise and Safety

FEDERAL REGULATIONS, EPA, PART 205; TRANSPORTATION EQUIPMENT NOISE EMISSION CONTROLS

Part 205, Transportation Equipment Noise Emission Controls, requires the vehicle manufacturer to furnish, with each new vehicle, such written instructions for the proper maintenance, use, and repair of the vehicle by the ultimate purchaser, to provide reasonable assurance of the elimination or minimization of noise emission degradation throughout the life of the vehicle. In compliance with the law, this section provides these instructions to owners.

Tampering

Federal law prohibits the following acts or the causing thereof:

- The removal or rendering inoperative by any person other than for purposes of maintenance, repair, or replacement of any device or element of design incorporated into any new vehicle for the purpose of noise control prior to its sale or delivery to the ultimate purchaser or while it is in use, or
- The use of the vehicle after such device or element of design has been removed or rendered inoperative by any person. Among those acts presumed to constitute tampering are the acts listed below:
- Removing or rendering the exhaust system components inoperative
- Removing or rendering the engine speed governor inoperative to allow engine speed to exceed the manufacturer's specifications
- Replacing the fan with an unauthorized fan
- Removing the radiator shield
- Removing the noise shields or acoustical absorptive material
- Removing air induction system components

Noise Control Maintenance

To maintain the noise control performance of your Freightliner vehicle, it must receive periodic inspections, maintenance, and service parts replacements. These services are included in the "Maintenance Jobs" section of the Driver's Manual and should be performed at every maintenance interval.

Please contact your Freightliner truck dealer if further details on servicing noise related components or other parts of your vehicle are necessary.

Freightliner Business Class M2

Cab and Chassis Vocational Reference Guide

General Information

Emission, Noise and Safety

INTERMEDIATE AND/OR FINAL STAGE MANUFACTURER RESPONSIBILITIES

It is the responsibility of the intermediate and/or final stage manufacturer to comply with all applicable laws and regulations pertaining to the manufacture and certification of equipment installations and/or vehicle modifications at time of certification. The intermediate and/or final stage manufacturer is solely responsible for the final certification of the vehicle and for compliance with EPA noise emissions requirements and Federal Motor Vehicle Safety Standards in effect on the stated date of manufacture.

The vehicle components listed below require special attention by the intermediate and/or final stage manufacturer:

1. No alteration or modification may be made to vehicle components forward of the rear cab wall unless they are approved component installations (such as air conditioning, radio, etc.) which are manufactured or endorsed by Freightliner.
2. The functional reliability and freedom of movement of all movable chassis components (e.g., axles, springs, driveshafts, steering systems, braking systems, gear-shift linkages, exhaust systems, etc.) must not be impaired by the installation of bodies or accessory equipment. This applies to the vehicle at rest and under operation.
3. The frame top and bottom flanges must not be drilled, altered or damaged in any way.
4. The vehicle braking and steering systems are safety related components. Anyone making changes or modifications to any component of these systems must assume complete responsibility for that system and its operation.
5. The operational reliability, roadworthiness and driveability of the vehicle must not be impaired by body or accessory equipment installation.

If any vehicle modifications or equipment installations have been performed, we advise that to the extent these modifications or equipment installations adversely affect other vehicle components or vehicle performance, we will be unable to accept any product liability or claims under the vehicle warranty and any such adverse affects therefore become the sole responsibility of the person performing the modifications or equipment installations.

Any manufacturer that makes material alterations to this incomplete vehicle during the process of manufacturing the complete vehicle should constantly recognize all the effects, either direct or indirect, on other components, assemblies, or systems caused by such alteration. No alterations should be made to the incomplete vehicle which either directly or indirectly results in any component, assembly or system being in noncompliance with any Emission Control Standard or Federal Motor Vehicle Safety Standard, or which would otherwise cause the vehicle to be or become defective or unsafe.

Advice concerning compliance with the U.S. Motor Vehicle Safety Act standards and regulations should be obtained from your legal counsel, the National Highway Traffic Safety Administration, or Transport Canada, as applicable.

Radio Frequency Interference RFI

Devices that emit radio frequency (RF) energy, such as AM/FM radios and radio-controlled security systems, marketed for sale or use in the United States are subject to the rules and regulations of the Federal Communications Commission (FCC). 47 C.F.R. Parts 2 and 15.

To insure continued compliance with the FCC's requirements, the owner, user, custom manufacturer, or service technician must not modify or change the RF device in a manner not expressly approved by Freightliner Truck Corporation. Such modifications could void the authority to operate the device.

Freightliner Business Class M2

Cab and Chassis Vocational Reference Guide

Emission, Noise and Safety

General Information

Labels

Noise Control Information

A label stating compliance with U.S. Environmental Protection Agency Noise Emission Standards is attached to the left side door sill below the striker, for complete vehicles certified by Freightliner.

Please consult the Maintenance Booklet supplied with each vehicle for cautionary information pertaining to compliance with Federal Regulation, EPA, Part 205: Transportation Equipment Noise Emission Standards.

Vehicle Document Information

Federal requirements regarding certification of compliance to Federal Motor Vehicle Safety Standards (FMVSS) for vehicles manufactured in two or more stages are contained in parts 567 and 568 of Title 49 of the code of Federal Regulations. The purpose of these regulations is to ensure that each completed motor vehicle will have a permanently affixed label certifying that such vehicle conforms to all applicable FMVSS in effect on the stated date of manufacture (see the following examples).

The incomplete vehicle document, enclosed in an envelope, is in the cab when the vehicle is released from Freightliner Truck Corporation (see the following examples).

Vehicle Emission Control Information

Freightliner provides each complete and incomplete vehicle with a separate VEHICLE EMISSION CONTROL INFORMATION LABEL, identifiable by its part number and content, inside the cab. These are described on pages 1-2 and 1-7.

Freightliner Business Class M2

Cab and Chassis Vocational Reference Guide

General Information

Label Location and Attachment Requirements

COMPONENT INFORMATION

 COMPONENT INFORMATION		USE VEHICLE ID NUMBER WHEN ORDERING PARTS
MANUFACTURED BY	FREIGHTLINER TRUCK PLANT MOUNT HOLLY LLC MT. HOLLY, NORTH CAROLINA	
MODEL	MM106042S	BASE MODEL: M2106
VEHICLE ID NO.	1FVACXBS39HAE4952	CUSTOMER: P54442
ENGINE MODEL	CUM ISC-300 300 HP / 2000 RPM:2200 GOV	ENGINE NO.
MAIN TRANS MOD	ALLISON 3000 RDS AUTOMATIC TRANSMISSION	TRANS NO.
FIRE PUMP MOD		FIRE PUMP NO.
FRONT AXLE MOD	AF-12. 0-3 12,000# FF1 71.5 KPI/3.74 DROP	FRONT AXLE NO.
1ST INT AXLE MOD		1ST INT AXLE NO.
2ND INT AXLE MOD		2ND INT AXLE NO.
3RD INT AXLE MOD		3RD INT AXLE NO.
4TH INT AXLE MOD		4TH INT AXLE NO.
5TH INT AXLE MOD		5TH INT AXLE NO.
6TH INT AXLE MOD		6TH INT AXLE NO.
REAR AXLE MOD	MERITOR RS-21-145 21,000# R-SRS	REAR AXLE NO.
PAINT MFR.	ELITE SS PAINT C	RATIO
PAINT NUMBER	CAB COLOR A: N0006EA WHITE ELITE SS	
		FOR COMPLETE PAINT INFORMATION SEE VEHICLE SPECIFICATION SHEET.
		L PART NO. 24-01177-010 REV A

One copy is in the Warranty Book and one copy is in the dash panel storage compartment

Freightliner Business Class M2 Cab and Chassis Vocational Reference Guide

General Information

Label Location and Attachment Requirements

VEHICLE NOISE EMISSION CONTROL INFORMATION (U.S. ONLY)

	VEHICLE NOISE EMISSION CONTROL INFORMATION	
FREIGHTLINER MT. HOLLY LLC	DATE OF MANUFACTURE	5/08
THIS INCOMPLETE VEHICLE, AS DELIVERED BY FREIGHTLINER LLC, CONFORMS TO U.S. EPA REGULATIONS FOR NOISE EMISSION APPLICABLE TO MEDIUM AND HEAVY TRUCKS. IT IS THE RESPONSIBILITY OF THE FINAL STAGE MANUFACTURER TO COMPLETE THIS VEHICLE WHILE MAINTAINING CONFORMANCE TO 40 CFR PART 205, INCLUDING LABELING FOR COMPLIANCE (SEC. 205. 55-4).		

Affixed to the left side door sill below striker

INCOMPLETE VEHICLE

THIS CHASSIS-CAB CONFORMS TO FEDERAL MOTOR VEHICLE SAFETY STANDARDS 101,102,103,104,106,107,111,113,120,105/121,124,205,206,207,208,209,210 & 302. CONFORMITY TO OTHER SAFETY STANDARDS APPLICABLE TO THIS VEHICLE WHEN COMPLETED IS NOT SUBSTANTIALLY AFFECTED BY THE DESIGN OF THE CHASSIS-CAB. IF COMPLETED IN ACCORDANCE WITH INSTRUCTIONS IN THE INCOMPLETE VEHICLE DOCUMENT PURSUANT TO 49CFR,PART 568, THIS VEHICLE WILL CONFORM TO FMVSS 108.	TYPE: TRUCK MANUFACTURED BY: FREIGHTLINER MT. HOLLY LLC VEHICLE ID NO.: 2FZHCHBS68AY54419 DATE OF MFR.: 5/08 GVWR-KG: 14,686 GVWR-LBS: 33,000	FRONT AXLE FIRST INT AXLE SECOND INT AXLE THIRD INT AXLE FOURTH INT AXLE FIFTH INT AXLE SIXTH INT AXLE REAR AXLE	GAWR-KGS: 5,443 GAWR-LBS: 12,000	TIRES: 11R22.5(G) RIMS: 22.5X8.25 KPA COLD: 724 PSI COLD: 105	*S*INGLE/*D*UAL S D
			GAWR-KGS: 9,525 GAWR-LBS: 21,000	TIRES: 11R22.5(G) RIMS: 22.5X8.25 KPA COLD: 724 PSI COLD: 105	*S*INGLE/*D*UAL D

Affixed to the left side door sill

Freightliner Business Class M2 Cab and Chassis Vocational Reference Guide

General Information

Label Location and Attachment Requirements

TIRE AND RIM INFORMATION

MAXIMUM GVW BY COMPONENT (KG) LB	COMPONENT	FRONT AXLE	FIRST INT AXLE	SECOND INT AXLE	THIRD INT AXLE	FOURTH INT AXLE	FIFTH INT AXLE	SIXTH INT AXLE	REAR AXLE	COMPONENT GVW
		AXLE	(5443) 12000							(9525) 21000
	SUSPENSION	(5443) 12000							(9525) 21000	ENG/TRANS (36288) 80000
	TIRES	(5601) 12350							(10596) 23360	5TH WHL
	RIMS	(6622) 14600							(13426) 29600	PARK BRAKE
	HUBS/SPOKES	(6350) 14000							(11793) 26000	AXLE
	BRAKES	(6032) 13300							(9979) 22000	
	STEERING	(6032) 13300								

VIN 1FVACXB539HAE4952 PART NO. 24-01177-080 REV A



Affixed to the right side door sill

Engine Exhaust Emission Compliance Certification is contained on the label installed on each engine assembly by the engine manufacturer. Location of the label for each engine manufacturer is shown below.

MANUFACTURER	ENGINE	LOCATION
Cummins	All	Front Gear Housing on Fuel Pump Side
Mercedes-Benz	All	Valve Cover

Freightliner Business Class M2

Cab and Chassis Vocational Reference Guide

General Information

Federal Motor Vehicle Safety Standards (FMVSS) & Canadian Motor Vehicle Safety Standards (CMVSS)

The purpose of this information and the following summarized text is to assist you in interpreting the Federal Motor Vehicle Safety Standards (FMVSS) and Canadian Motor Vehicle Safety Standards (CMVSS) for vehicles and how they apply to the sale of Freightliner Medium and Heavy Duty trucks sold in the U.S. and Canada.

Vehicles sold for delivery in the U.S. are manufactured by Freightliner Trucks for completion in compliance with the U.S. Federal Motor Vehicle Safety Standards. The Canadian Motor Vehicle Safety Standards will apply to vehicles sold in Canada.

The FMVSS and CMVSS regulations control the manufacture and sale of motor vehicles and their usage. Other laws apply to the application and use of vehicles. Owners or operators using vehicles are responsible for those vehicles meeting certain legal requirements. The MVSS laws, by contrast, put the burden of obeying the law on the manufacturer, dealer, or body manufacturer who sells the completed vehicle to the end user. For this reason, it is important that all concerned parties review information carefully to ensure compliance with the MVSS laws and related safety standards. It is recommended that dealers and others concerned review this information with their legal counsel.

No modification or addition to the vehicle can be made which causes noncompliance with any FMVSS or CMVSS, as applicable, as certified by Freightliner Truck Corporation.

Freightliner LISTS EACH STANDARD WITH A DESCRIPTION OF CERTIFICATION.

FMVSS 101 / CMVSS 101

This vehicle, when completed, will conform to FMVSS / CMVSS No. 101, Control Location Identification and Illumination, if no alterations are made to the vehicle controls including their location, means of identification and method of illumination.

Vehicle and system control, including but not limited to:

STEERING WHEEL	HIGH BEAM
HORN CONTROL	HEATING SYSTEM CONTROLS
TRANSMISSION SHIFT LEVER	HAZARD WARNING FLASHER
IGNITION SWITCH	CLEARANCE LIGHT CONTROL
HEADLIGHT SWITCH	HAND THROTTLE
TAIL LIGHT	IDENTIFICATION LIGHT CONTROL
TURN SIGNAL CONTROL	SERVICE BRAKE
ILLUMINATION INTENSITY RHEOSTAT	ACCELERATOR
WINDSHIELD WIPER/WASHER CONTROL	CLUTCH
DRIVER'S SUN VISOR	WINDSHIELD DEFROSTING AND DEFOGGING SYSTEM CONTROL
AUTOMATIC VEHICLE SPEED SYSTEM	

FMVSS 102 / CMVSS 102

This vehicle, when complete, will conform to FMVSS / CMVSS No. 102, Transmission Shift Lever Sequence, Starter Interlock and Transmission Braking Effect, if no alterations are made to the shift pattern display(s). If the vehicle is equipped with an automatic transmission, the vehicle will conform if no alterations are made in the transmission, transmission controls, connecting linkages, and cables, starting motor, starting motor wiring or plumbing, neutral safety switch and ignition or equivalent switch and related wiring, and shift lever position identifications.

Freightliner Business Class M2

Cab and Chassis Vocational Reference Guide

General Information

Federal Motor Vehicle Safety Standards (FMVSS) & Canadian Motor Vehicle Safety Standards (CMVSS)

FMVSS 103 / CMVSS 103

This vehicle, when complete, will conform to FMVSS / CMVSS No. 103, Windshield Defrosting and Defogging Systems, if no alterations are made in the windshield defrosting and defogging systems, controls, wiring, plumbing and air flow to the windshield.

Windshield and Defrosting Systems, including but not limited to:

WINDSHIELD ASSEMBLY	HEATER CONTROLS
HEATER AND DEFROSTER ASSEMBLY - INCLUDING MOTOR AND BLOWER	CHASSIS AND INSTRUMENT WIRING HARNESS BLOWER MOTOR RESISTOR
HEATER AND WATER HOSES AND HOSE ASSEMBLIES AND ROUTING	HEATER CORE WATER VALVE
DEFROSTER NOZZLES	ENGINE WATER OUTLET THERMOSTAT
DEFROSTER DUCTS	

FMVSS 104 / CMVSS 104

This vehicle, when complete, will conform to FMVSS / CMVSS No. 104, Windshield Wiping and Washing Systems, if no alterations are made in the windshield wiper arms, blades, washer, controls, wiring, or plumbing.

Windshield Wiping and Washing Systems, including but not limited to:

WINDSHIELD ASSEMBLY	WINDSHIELD WIPER
WINDSHIELD WIPER ARM ASSEMBLY	WINDSHIELD WASHER FLUID RESERVOIR
WINDSHIELD WIPER BLADE ASSEMBLY	WASHER RESERVOIR CAP
WINDSHIELD WIPER LINKAGE ASSEMBLY	WINDSHIELD WASHER NOZZLE
WINDSHIELD WIPER AND WASHER CONTROL	CHASSIS WIRING HARNESS
WINDSHIELD WIPER AND WASHER	MOTOR AND PUMP ASSEMBLY

Note: Dimensions in parentheses are millimeters

FMVSS 105 / CMVSS 105

This vehicle, when complete, will conform to FMVSS / CMVSS No. 105, Hydraulic Braking System Components and Fittings, if it does not exceed any of the gross axle or gross vehicle weight ratings and if no alterations or changes are made in, to the anti-lock system components or electrical circuitry (if present); tire size and wheelbase.

FMVSS 106 / CMVSS 106

This vehicle, when complete, will conform to FMVSS / CMVSS No. 106, Brake Hoses, if no alterations are made to the air or hydraulic brake hoses, brake hose assemblies, and brake hose fittings including the labeling on these components.

FMVSS 107 / CMVSS 107

This vehicle, when complete, will conform to FMVSS / CMVSS No. 107, Reflecting Surfaces, if no alterations are made in the windshield wiper arms or blades, in the inside windshield mouldings, and in the horn ring and hub of the steering wheel assembly. If an inside rearview mirror is installed by any subsequent manufacturer, it shall be the responsibility of that manufacturer to ensure that the specular gloss of the surface of the inside rearview mirror frame and mounting bracket conforms to the requirements of this standard.

FMVSS 108 / CMVSS 108

For Truck Tractor

This vehicle, when manufactured as a truck tractor, will conform to FMVSS / CMVSS No. 108, Lamps, Reflective Devices, and Associated Equipment, if no alterations are made to any associated items supplied on the vehicle and no obstructions are installed which limit visibility of any item.

For Truck

Conformity with FMVSS / CMVSS 108, Lamps, Reflective Devices, and Associated Equipment, is not substantially determined by the design of this chassis cab. The manufacturer makes no representation to conformity with the standard.

Freightliner Business Class M2

Cab and Chassis Vocational Reference Guide

General Information

Federal Motor Vehicle Safety Standards (FMVSS) & Canadian Motor Vehicle Safety Standards (CMVSS)

FMVSS 111 / CMVSS 111

This vehicle, when complete, will conform to FMVSS / CMVSS No. 111, Rearview Mirrors, if no alterations are made to mirrors, mounts, locations, or cab structure and no obstructions are installed which limit usage.

FMVSS 113 / CMVSS 113

For Conventional Model Vehicles

This vehicle, when complete, will conform to FMVSS / CMVSS No. 113, if no alterations are made in the Hood Latch System, including the attachments for the hood latches.

HOOD FRONT REINFORCEMENT SUB-ASSEMBLY	HOOD LOCK CONTROL CABLE ASSEMBLY
HOOD LOCK ASSEMBLY	

For Cab Forward or COE Vehicles

This standard is not applicable to this vehicle.

FMVSS 115 / CMVSS 115

This vehicle, when complete, will conform to FMVSS / CMVSS No. 115, Vehicle Identification Number, if no alterations are made to the identification number. VIN coding information for Freightliner trucks is shown on pages 1-15 and 1-16 of this manual.

FMVSS 116 / CMVSS 116

This vehicle, when complete, will conform to FMVSS / CMVSS No. 116, Motor Vehicle Brake Fluid, if no changes are made that affect the physical or chemical properties of the brake fluid. Use only heavy duty fluid, DOT 3, in the hydraulic brake system if additional fluid is needed.

FMVSS 120 / CMVSS 120

This vehicle, when complete, will conform to FMVSS / CMVSS No. 120, Tire Selection and Rims for Motor Vehicles Other Than Passenger Cars, if no changes are made to the tires, rims, or labeling.

FMVSS 121 / CMVSS 121

This vehicle, when complete, will conform to FMVSS / CMVSS No. 121, Air Brake System, if it does not exceed any of the gross axle or gross vehicle weight ratings, and if no alterations or changes are made in, or affect the air system components, or circuitry (if present); electric wire circuit or components associated with the above, tire size and wheelbase.

FMVSS 124 / CMVSS 124

This vehicle, when complete, will conform to FMVSS / CMVSS No. 124, Accelerator Control System, if no alterations are made to any components of the throttle control or fuel metering system.

FMVSS 205 / CMVSS 205

This vehicle, when complete, will conform to FMVSS / CMVSS No. 205, Glazing Materials, if no alterations are made in the glazing material installed in the windshield and windows of the cab.

FMVSS 206 / CMVSS 206

This vehicle, when complete, will conform to FMVSS / CMVSS No. 206, Door Locks and Door Retention Components, if no alterations are made in the door assembly, door latches, door striker assemblies, door hinges, door locks, door latch posts, door hinge posts, and supporting cab structure.

FMVSS 207 / CMVSS 207

This vehicle, when complete, will conform to FMVSS / CMVSS No. 207, Seating Systems, if no alterations are made to the seats, seat adjusters, restraining devices, release and adjustment controls, seat risers, and supports, and the cab floor and supporting structure.

Freightliner Business Class M2

Cab and Chassis Vocational Reference Guide

General Information

Federal Motor Vehicle Safety Standards (FMVSS) & Canadian Motor Vehicle Safety Standards (CMVSS)

FMVSS 208 / CMVSS 208

This vehicle, when complete, will conform to FMVSS / CMVSS No. 208, Occupant Crash Protection, if no change is made in the number of designated occupants' seating positions provided, and if no alterations are made in the cab and supporting structure, cab underbody, seat belt assemblies, seat belt anchorages, seats, and seating anchorages.

FMVSS 209 / CMVSS 209

This vehicle, when complete, will conform to FMVSS / CMVSS No. 209, Seat Belt Assemblies, if no alterations are made in the seat belt assemblies, seat belt anchorages and attachments, and the cab structure to which the anchorages are attached.

FMVSS 210 / CMVSS 210

This vehicle, when complete, will conform to FMVSS / CMVSS No. 210, Seat Belt Assembly Anchorages, if no additional occupant seats or seat belt assembly anchorages are added and if no alterations are made which affect the function, physical, or mechanical properties, environmental or vital clearance of the components, assemblies or systems identified below:

Seat Belt Systems, including but not limited to:

SEAT ASSEMBLIES	FLOOR PLAN ASSEMBLIES
SEAT BELT ROUTING	SEAT BELT ASSEMBLIES
SEAT POSITION AND/OR ADJUSTMENT CAPABILITY	SEAT BELT ANCHORAGE BRACKETS AND/OR REINFORCEMENT

FMVSS 302 / CMVSS 302

This vehicle, when complete, will conform to FMVSS / CMVSS No. 302, Flammability of Interior Materials, if no alterations are made to the materials, including the surface material and padding or cushioning used in the interior of the vehicle's occupant compartment including but not limited to the following components: seat cushions, seat backs, seat belts, arm rests, all trim panels including door, front, rear, and side panels, compartment shelves, floor covering, headlining, sun visors, curtains, shades, engine compartment cover, mattress covers, and other interior materials, including padding that is designed to absorb energy on contact by occupants in the event of a crash.

If the intermediate or final stage manufacturer installs any of the aforementioned items, those items must also meet the requirements of this standard.

Summary

The final stage manufacturer must complete the vehicle in such a manner that it conforms to all standards in effect on the date of manufacture by Freightliner Truck Corporation, the date of final completion or a date between those two dates.

Freightliner Business Class M2 Cab and Chassis Vocational Reference Guide

General Information

Used in the U.S. National Traffic and Motor Vehicle Safety Act or Regulations Thereunder

Assembler

means a manufacturer engaged in the business of altering vehicles that bear the National Safety Mark.

Chassis Cab

means an incomplete vehicle, with a completed occupant compartment, that requires only the addition of cargo-carrying, work-performing or load-bearing components to perform its intended functions.

Completed Vehicle

means a vehicle that requires no further manufacturing operations to perform its intended function, other than the addition of readily attachable components, such as mirrors or tire and rim assemblies, or minor finishing operations such as painting.

Dealer

means any person who is engaged in the sale and distribution of new motor vehicles or motor vehicle equipment primarily to purchasers who in good faith purchase any such vehicle or equipment for purposes other than resale.

Final-Stage Manufacturer

means a person who performs such manufacturing operations on an incomplete vehicle that it becomes a completed vehicle.

Gross Axle Weight Rating (GAWR)

means the value specified by the vehicle manufacturer as the load carrying capacity of a single axle system as measured at the tire-ground interfaces.

Gross Vehicle Weight Rating (GVWR)

means the value specified by the vehicle manufacturer as the loaded weight of a single vehicle.

Incomplete Vehicle

means an assemblage consisting, as a minimum, of frame and chassis structure, power train, steering system, suspension system, and braking system, to the extent that those systems are to be part

Definitions of Terms

of the completed vehicle, that requires further manufacturing operations, other than the addition of readily attachable components, such as mirrors or tire and rim assemblies, or minor finishing operations such as painting, to become a completed vehicle.

Manufacturer

means any person engaged in the manufacturing or assembling of motor vehicles or motor vehicle equipment, including any person importing motor vehicles or motor vehicle equipment for resale.

Truck

means a motor vehicle with motive power, except a trailer, designed primarily for the transportation of property or special purpose equipment.

Truck Tractor

means a truck designed primarily for drawing other motor vehicles (semi-trailers) and not so constructed as to carry a load other than a part of the weight of the vehicle and the load so drawn.

Unloaded Vehicle Weight (UVW)

means the weight of a vehicle with maximum capacity of all fluids necessary for operation of the vehicle, but without cargo, occupants, or accessories that are ordinarily removed from the vehicle when they are not in use.

Vehicle Alterer

as used in this book means a person who alters a vehicle that has previously been certified in accordance with Section 567.4 or 567.5 of Title 49 Code of Federal Regulations other than by the addition, substitution or removal of readily attachable components such as mirrors or tire and rim assemblies, or minor finishing operations such as painting, or who alters the vehicle in such a manner that its stated weight ratings are no longer valid, before the first purchase of the vehicle in good faith for purposes other than resale.

Vehicle Capacity Mass

means the rated cargo and luggage mass plus 150 pounds (70kg) multiplied by the designated seating capacity.

Freightliner Business Class M2

Cab and Chassis Vocational Reference Guide

General Information

Freightliner VIN Coding – Summary Sheet

Example of VIN	1	F	V	A	C	X	B	S	3	9	H	A	1	2	3	4	5
POSITION	1	2	3	4	5	6	7	8	9	10	11	12	13	14	15	16	17
DECODING TABLE	A			B	C	D			E	F	G	Serial Number					

WORLD MANUFACTURER IDENTIFICATION – POSITIONS 1 • 2 • 3

CODE	MANUFACTURER	MAKE	TYPE
1FU	Freightliner Corp.	Freightliner	Truck
1FV	Freightliner Corp.	Freightliner	Incomplete Vehicle

CHASSIS – Position 4

CODE	CONFIGURATION	CHASSIS
A	4 X 2	TRUCK
B	4 X 2	TRUCK-TRACTOR
D	4 X 4	TRUCK
E	4 X 4	TRUCK-TRACTOR
F	6 X 2	TRUCK
G	6 X 2	TRUCK-TRACTOR
H	6 X 4	TRUCK
J	6 X 4	TRUCK-TRACTOR
K	6 X 6	TRUCK
L	6 X 6	TRUCK-TRACTOR
X	GLIDER	GLIDER

MODEL, CAB, GVWR – Position 5 • 6

CODE	MODEL	CAB	GVWR
CS	M2 100	CONVENTIONAL	14,001 X 16,000 LB • CLASS 4
CT	M2 100	CONVENTIONAL	16,001 X 19500 LB • CLASS 5
CU	M2 100	CONVENTIONAL	19,501 X 26,000 LB • CLASS 6
CV	M2 106 MEDIUM DUTY	CONVENTIONAL	16,001 X 19,500 LB • CLASS 5
CW	M2 106 MEDIUM DUTY	CONVENTIONAL	19,501 X 26,000 LB • CLASS 6
CX	M2 106 MEDIUM DUTY	CONVENTIONAL	26,001 X 33,000 LB • CLASS 7
CY	M2 106 MEDIUM DUTY	CONVENTIONAL	33,001 LBS AND OVER • CLASS 8
CZ	M2 106 V HEAVY DUTY	CONVENTIONAL	16,001 X 19,500 LB • CLASS 5
C1	M2 106 V HEAVY DUTY	CONVENTIONAL	19,501 X 26,000 LB • CLASS 6
C2	M2 106 V HEAVY DUTY	CONVENTIONAL	26,001 X 33,000 LB • CLASS 7
C3	M2 106 V HEAVY DUTY	CONVENTIONAL	33,001 LBS AND OVER • CLASS 8
C4	M2 112 MEDIUM DUTY	CONVENTIONAL	26,001 X 33,000 LB • CLASS 7
C5	M2 112 MEDIUM DUTY	CONVENTIONAL	33,001 LBS AND OVER • CLASS 8
C6	M2 112 V HEAVY DUTY	CONVENTIONAL	26,001 X 33,000 LB • CLASS 7
C7	M2 112 V HEAVY DUTY	CONVENTIONAL	33,001 LBS AND OVER • CLASS 8
C8	M2 106 MEDIUM DUTY	CONVENTIONAL	14,001 X 16,000 LB • CLASS 4
F8	M2 106 MEDIUM GLIDER	CONVENTIONAL	GLIDER
FC	M2 106 SPORT CHASSIS	CONVENTIONAL	16,001 X 19500 LB • CLASS 5
FD	M2 106 SPORT CHASSIS	CONVENTIONAL	19,501 X 26,000 LB • CLASS 6
FE	M2 106 SPORT CHASSIS	CONVENTIONAL	26,001 X 33,000 LB • CLASS 7

Freightliner Business Class M2

Cab and Chassis Vocational Reference Guide

General Information

Freightliner VIN Coding – Summary Sheet

Example of VIN	2	F	W	P	E	C	Y	B	3	X	A	3	4	5	6	7	8
POSITION	1	2	3	4	5	6	7	8	9	10	11	12	13	14	15	16	17
DECODING TABLE	A		B	C		D		E	F	G	Serial Number						

ENGINE, BRAKES – Position 7 • 8					
CODE	ENGINE	FUEL	DISPLACEMENT	CONFIG	BRAKES
BS	Cummins ISC	Diesel	8.3 liter	I-6	Air
BT	Cummins ISC	Diesel	8.3 liter	I-6	Hydraulic
BU	Cummins ISC	Diesel	8.3 liter	I-6	Air over Hyd
CN	Mercedes-Benz MBE-900	Diesel	4.3 liter	I-4	Air
CP	Mercedes-Benz MBE-900	Diesel	4.3 liter	I-4	Hydraulic
CR	Mercedes-Benz MBE-900	Diesel	4.3 liter	I-4	Air over Hyd
CS	Mercedes-Benz MBE-900	Diesel	6.4 liter	I-6	Air
CT	Mercedes-Benz MBE-900	Diesel	6.4 liter	I-6	Hydraulic
CU	Mercedes-Benz MBE-900	Diesel	6.4 liter	I-6	Air over Hyd
CV	Mercedes-Benz MBE-4000	Diesel	12.8 liter	I-6	Air
CW	Mercedes-Benz MBE-4000	Diesel	12.8 liter	I-6	Hydraulic
CX	Mercedes-Benz MBE-4000	Diesel	12.8 liter	I-6	Air over Hyd
DG	Mercedes-Benz MBE-900	Diesel	4.8 liter	I-4	Air
DH	Mercedes-Benz MBE-900	Diesel	4.8 liter	I-4	Hydraulic
DJ	Mercedes-Benz MBE-900	Diesel	7.2 liter	I-6	Air
DK	Mercedes-Benz MBE-900	Diesel	7.2 liter	I-6	Hydraulic
DT	Cummins ISB	Diesel	6.7 liter	I-6	Air
DU	Cummins ISB	Diesel	6.7 liter	I-6	Hydraulic

Freightliner Business Class M2

Cab and Chassis Vocational Reference Guide

General Information

CHECK DIDGIT - POSITION 9

CALCULATED FROM A MATHEMATICAL COMPUTATION
OF ALL OTHER VIN CHARACTERS

MODEL YEAR - Position 10

CODE	MODEL YEAR
5	2005
6	2006
7	2007
8	2008
9	2009
A	2010
B	2011
C	2012
D	2013

SERIAL NUMBER - POSITION 12-17

SEQUENTIALLY ASSIGNED VEHICLE SERIAL NUMBER

Freightliner VIN Coding - Summary Sheet

BUILD LOCATION - POSITION 11

CODE	BUILD LOCATION
H	MT. HOLLY, NC
D	M-B MEXICO, SANTIAGO

Freightliner Business Class M2 Cab and Chassis Vocational Reference Guide

General Information

Rollover stability is an important factor which can influence the safe performance of the truck. Stability is influenced by many factors including chassis and body configuration, suspension, axle track width, tire size, tire pressure, etc. The cargo type and weight (payload), the body size, shape, and center of gravity height are particularly important.

A guideline for rollover stability has been established in research conducted for the National Highway Traffic Safety Administration (NHTSA). This guideline is a value of lateral acceleration (0.35 g) corresponding to a certain speed, in a turn of a given radius, at which a truck will roll over. Freightliner has analyzed how this guideline relates to certain configurations and specifications which we produce for on-highway applications. Specialized configurations such as 4 x 4 and 6 x 6 all wheel drives, plus vehicles with loaded frame heights over 44 inches, are not covered.

Freightliner vehicles rated up to 52,000 pounds GVWR, with Freightliner suspensions, conform to this guideline if the center of gravity of the combined body and maximum payload added to the Freightliner chassis is not higher than 75.00 inches (1905.0 mm) above level ground for a vehicle/payload combination that loads the truck to its full gross vehicle weight (GVWR). For body and payload combinations that do not load the truck to 100% of its GVWR, the following graph can be used to determine the maximum allowable height of the combined body and payload center of gravity. These limits apply to payloads that are stable and laterally centered.

If a vehicle configuration approaches or exceeds the limits shown on the graph, changes to the design of the vehicle should be considered. Two of the more effective modifications include specifying a wide track rear axle and, in certain cases, increasing the capacity of the rear suspension. The following graph shows that the use of a wide track rear axle results in a higher allowable CG for the combined body and payload.

Vehicle Rollover Stability Guideline

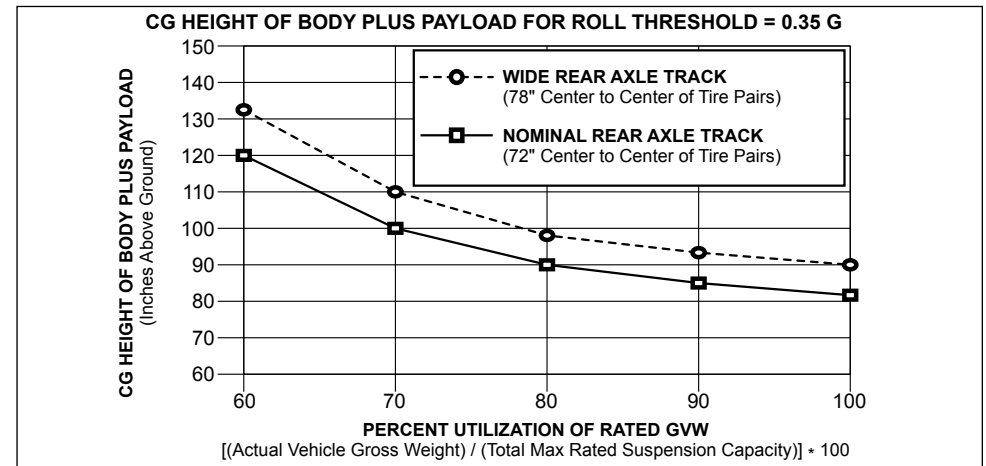

NOTE: Conformance to this guideline does not ensure that a vehicle will be stable if safe operating practices are not followed. For example, excessive speed in turns or on nonlevel surfaces, unstable or offset loads, etc., can cause instability. Also, other factors influence handling and subjective feel such as suspension roll stiffness and steering geometry. These may influence drivers' perceptions of whether a vehicle has satisfactory stability.

IMPORTANT: Calculations of rollover stability are approximations. Confirmatory testing may be necessary in marginal circumstances. SAE J2180, a tilt table measurement procedure, can be utilized to more accurately establish rollover threshold.

WARNING: Always consider rollover threshold when specifying a truck chassis and installing or modifying a body or major equipment. Otherwise, the vehicle could be unstable in curves or other steering maneuvers, possibly resulting in rollover and serious personal injury or death.

Additional information can be obtained from Freightliner Truck Application Engineering at 503-745-4636.

Freightliner Business Class M2

Cab and Chassis Vocational Reference Guide

General Information

SUSPENSION - FRONT AND REAR

1. No drilling or welding to the front axle "I" beam is permissible. Special equipment mounting or attaching brackets, requiring attachment to the front axle, may be clamped to axle "I" beams only.
2. Front or rear suspension member components should not be modified or relocated for any reason.

AIR BRAKES

Freightliner air brake equipped incomplete vehicle products to the extent completed, comply with Federal Motor Vehicle Safety Standard 121, "Air Brake Systems."

The statements contained in this section regarding FMVSS-121 compliance are accurate at the time of printing. However, these statements are not intended to replace the statements regarding FMVSS-121 in the Incomplete Vehicle Manual; consequently, that manual should be consulted for compliance conditions.

Following are components and characteristics of the completed vehicle which are critical to overall performance of air braked vehicles. These items should be carefully considered in ordering a vehicle as well as planning vehicle completion by a subsequent stage manufacturer(s) to insure compliance (final certification) of the completed vehicle to FMVSS-121, as well as completed vehicle integrity.

Center of Gravity

The vertical center of gravity of the completed vehicle has a direct effect on the vehicle's stopping distance capability. As the vertical center of gravity increases or the wheelbase decreases, additional weight is transferred to the front axle during a stop, affecting the stopping distance. The Heavy Truck Incomplete Vehicle Document specifies that Trucks and Buses completed from chassis cabs and chassis cowl shall have center of gravity height/wheelbase ratios of 0.50 or less when loaded to a weight not exceeding GVWR* distributed proportionately to, but not exceeding GAWR's* or, as measured from the ground to the center of gravity of the vehicle/payload combination, the center of gravity height must not exceed 70 inches on single rear axle vehicles or 75 inches on tandem rear axle vehicles, whichever is less.

Note: Dimensions in parentheses are millimeters

Truck Body and Special Equipment Installation Precautions

As a guide, the vertical center of gravity height of the incomplete vehicle, as manufactured by Freightliner Trucks, may be assumed to be the distance from the ground to the top of the frame side rail measured at the longitudinal midpoint of the vehicle in the unladen condition for single axle vehicles and laden condition for tandem axle vehicles.

The frame rail height may be calculated from the chassis diagrams in this publication. Also, if you are measuring an unloaded chassis, you may assume the loaded frame rail height to be two inches lower than the bare chassis.

Vehicles completed as trucks could require a vertical center of gravity lower than the recommendations above based on the stability considerations of certain vocational body and/or usage situations. The above recommendations consider only vehicle brake performance.

If higher vertical center-of-gravity limitations are required for a specific vocational body or application, contact your Freightliner District Sales Manager, or submit all chassis specifications along with body and payload information in a request for advice to:

Freightliner Trucks
Customer Application Engineering
2477 Deerfield Dr.
Ft. Mill, SC 29715

NOTE: *GVWR and GAWR's as indicated on the cover of the Incomplete Vehicle Document provided with the records.

Freightliner Business Class M2

Cab and Chassis Vocational Reference Guide

General Information

ENGINE AND ENGINE ACCESSORIES

Modifications to the engine-driven air compressor, the drive speed ratio of the air compressor, or the engine-governed RPM will directly affect the ability of the compressor to build up air brake system pressure. FMVSS-121 contains specific air brake system pressure build-up performance requirements which could be adversely affected by any of these modifications. Consequently, the representation as to conformity to FMVSS-121 provided in the Incomplete Vehicle Manual is conditional upon none of the above-mentioned modifications being made.

Air-Functioned Accessories

FMVSS-121 contains a pressure build-up performance requirement which states that the system pressure must build up from 85 to 100 psi in a specific time period under certain conditions. Therefore, the addition of any accessory or its associated plumbing which increases the volume of air subject to the build-up requirement will increase the build-up time and may affect compliance with FMVSS-121.

The representation as to conformity of the completed vehicle to FMVSS-121 provided in the Incomplete Vehicle Document has the following conditions for air-operated accessories and associated plumbing added to a vehicle by a subsequent stage manufacturer.

- No connections are made into (1) the air line tubing or fittings for the parking brake system, (2) the rear axle emergency system (modulated spring brake system), (3) the air supply and signal lines to the rear chassis relay valve(s) or (4) the air delivery lines to the front axle brakes and quick release valve.
- No connections are made between the check valve and the reservoir port for air supply.
- Additional reservoir volume must be added with tag or pusher axles, etc. Added volume must be equal to 12 times the added brake chambers' rated volume.
- Each added reservoir shall be capable of withstanding an internal hydrostatic pressure of five times the compressor cutout pressure or 500 psi, whichever is greater, for 10 minutes.

Note: Dimensions in parentheses are millimeters

Truck Body and Special Equipment Installation Precautions

- Air for a pneumatic accessory should be sourced directly from an air reservoir. If an unused reservoir tap is not available, fittings added to the system at the reservoir must not restrict air flow to any existing air lines.

GENERAL GUIDELINES FOR CONNECTING TO AIR SYSTEM

The following are to be observed when adding air accessories.

Do's

The secondary air system is the preferred connection point for auxiliary devices. However, the primary system may be used if connections to the secondary system are impractical.

Connect to supply lines at or between service tanks and in-cab control valves only.

Add drain valves to additional reservoirs. Add pressure protection valves with a minimum rating of 55 psi for all added non-brake components

Do Not's

Do not connect to lines between air tanks and relay valve.

Do not connect to lines between foot valve and relay valves or front delivery to brakes (Delivery System).

Do not connect to spring brake lines or lines to emergency system spring brake valve.

Do not connect to supply tank or connecting lines.

Do not tap between check valve at supply line to air reservoir and reservoir port. Above guidelines apply to accessories only and should not be used for additional axle installations.

Freightliner Business Class M2

Cab and Chassis Vocational Reference Guide

General Information

Adding Brake Air Dryer Tanks and/or Additional Air Reservoirs

Brake air dryer tanks, where used, must meet the requirements of FMVSS-121 for reservoirs. They must have drain valves which can be operated manually.

Relocation of Air Reservoirs

Relocation of air reservoirs may be accomplished with the following precautions: All air lines and fittings are to be same size and material as original equipment with no kinking or air passage restrictions.

Original air reservoir volumes are not to be reduced.

Relocation of an air reservoir in a direction farther from the relay valve will require testing for compliance to FMVSS-121 -S5.3.3 and S5.3.4 Brake Application and Release Timing.

Relocation of Relay Valve

The relay valve may be relocated, if necessary, subject to the following restrictions:

Minor relocation without revisions to air lines would be acceptable provided no lines are kinked or restricted in size.

Routing of all hoses must provide clearance to axle, air lines, and other components, as well as ensure adequate hose length throughout all axle articulations.

Minor length changes and routings of air lines at the rear axle to air chambers are acceptable.

All fittings, hoses and air lines utilized for the modified installation must be of the same size and specification of the original equipment on the chassis, and installations must be free of kinks and restrictions.

All fasteners must be equivalent to the specifications of the original equipment.

A vehicle final-stage manufacturer or alterer who chooses to lengthen or shorten wheelbases on vehicles with FMVSS-121 air brakes should note that he is responsible for the modification, including revisions to the frame, driveline, wiring, plumbing, suspension, etc. The vehicle final-stage manufacturer or alterer must also certify the vehicle for compliance to FMVSS-121.

Note: Dimensions in parentheses are millimeters

Truck Body and Special Equipment Installation Precautions

Vehicle wheelbase modifiers should note the following conditions and instructions:

It is possible to shorten the wheelbase without adversely affecting air brake timing. However, tractors should not be shortened to a wheelbase shorter than the shortest offered by Freightliner Trucks with the same front and rear axle combination. Trucks, also, should not be shortened to a wheelbase shorter than the shortest offered by Freightliner Truck Corporation with the same front and rear axle combination for truck service.

It is possible to lengthen the wheelbase up to the maximum wheelbase offered by Freightliner Truck Corporation as a regular production option for that truck series without affecting air brake timing compliance. The plumbing for the modified wheelbase should be the same as used by Freightliner in regular production of that longer wheelbase. This will require following the air brake schematic as shown in this Freightliner Cab and Chassis Vocational Reference Guide and may require the addition of a quick release valve on the rear axle or to the relay valve signal line.

Vehicle GVWR and GAWR's

The representation as to conformity of the complete vehicle to FMVSS-121 provided in the Incomplete Vehicle Document is conditioned on the GVWR and the GAWR's of the completed vehicle being identical to the ratings designated on the front cover of the Incomplete Vehicle Document for the vehicle. The brake system on each air braked incomplete vehicle manufactured by Freightliner Trucks is designed to comply with FMVSS-121 when loaded to a specific completed vehicle GVWR distributed proportionate to specific GAWR's. Revised vehicle GVWR or GAWR's, or the addition of axles to the vehicle, will change loading conditions and may adversely affect compliance to FMVSS-121.

Freightliner Business Class M2 Cab and Chassis Vocational Reference Guide

General Information

Wheelbase Modifications

Persons intending to lengthen or shorten a vehicle frame and wheelbase are encouraged to contact Freightliner Truck Application Engineering at 503-745-6822 for precautionary recommendations prior to modification.

Any deviation from the original vehicle specification will become the responsibility of the subsequent stage manufacturer or installer. All fittings, hoses and air lines used on vehicles with modified wheelbases must be the same size and specification as the original equipment on the chassis.

There must be no kinking, added elbows, or other air passage restrictions. Any lengthening or splicing of wires should be in accordance with procedures described in the "Electrical Section" on page 1-24 of this section.

Tires

Tire size and tire traction characteristics (rubber composition and tread design) significantly affect vehicle stopping capability on both wet and dry road surfaces. Changes in tire size may also require the reprogramming of the vehicle ABS computer. Call Freightliner Truck Application Engineering at 503-745-6822 for additional information.

Consequently, the representation as to conformity of the completed vehicle to FMVSS-121 provided in the Incomplete Vehicle Document is conditioned on the tires on the completed vehicle being those installed by Freightliner Truck Corporation on the incomplete vehicle.

If the incomplete vehicle is fitted with temporary transportation tires, Freightliner Truck Corporation makes no representation as to conformity with FMVSS-121.

Truck Body and Special Equipment Installation Precautions

Suspension and Steering

The representation as to conformity of the completed vehicle to FMVSS-121 provided in the Incomplete Vehicle Manual is conditioned on no modifications being made by a subsequent stage manufacturer(s) to the suspension or steering systems of an incomplete vehicle which could in any way adversely affect vehicle or related brake system performance.

Addition of Tag or Pusher Axles - Air Braked Vehicles

Any deviation from the original vehicle specification will become the responsibility of the subsequent stage manufacturer or installer. If tag and pusher axles are added to Freightliner FMVSS-121 air brake truck chassis, the following conditions must be met for each installation:

Because of the added chamber volume accompanying the brakes on the added axle, the reservoir volume will have to be re-evaluated to ensure compliance to the 12X chamber volume criterion for reservoirs. Added reservoirs must meet the requirements of FMVSS-121.

It is the responsibility of the subsequent installer to ensure that brake actuation and release timing and compressor capacity requirements of the modified system are met. Physical testing may be required by the installer if a body of correlation data to support an engineering analysis is absent.

Engineering analysis should be made to ensure that the service, emergency and parking brake capabilities equal or exceed those of the base vehicle. If not, performance tests may be necessary to ensure compliance to the requirements of FMVSS-121.

Engineering analysis to determine compliance and any added certification or incomplete vehicle labels should use the GAWR's and GVWR of the base vehicle, showing the added axle at its rated GAWR.

Freightliner Business Class M2

Cab and Chassis Vocational Reference Guide

General Information

The test condition for vehicles with liftable axles will be with the axle up for unladen tests, and for laden tests, lowered so that it bears a load given by:

$$\text{GAWR of Liftable Axle} \times \frac{\text{GVWR of Vehicle}}{\text{Sum of GAWRs of All Axles}}$$

The addition of spring applied parking brakes to the tag or pusher axle may be required depending on the final GVWR and GAWR's of the completed vehicle. Engineering analysis must be made to ensure that the service, emergency and parking brake capabilities equal or exceed those of the base vehicle. If not, performance tests will be required to ensure compliance to the requirements of FMVSS-121.

The addition of a tag or pusher axle on a vehicle equipped with "ABS" may affect the overall brake performance of the vehicle.

When installing tag or pusher axles the following tap-in procedure is recommended:

Connect added reservoir (required to ensure compliance to the 12X chamber volume criterion) to the supply line for rear axle relay valve.

Connect signal line for added axle relay valve to existing rear axle valve signal line.

Add quick release valve to rear axle if brake release is too slow.

Supply and control ports for additional axle brake valves must be plumbed to the same system, e.g., both from primary system air or both from secondary air. Call Freightliner Truck Application Engineering prior to modification for recommendations as to which system to use. Freightliner Trucks may not honor the warranties of vehicles for which GVWR's have been increased by aftermarket installation of tag or pusher axles.

Truck Body and Special Equipment Installation Precautions

AUTOMATIC TRANSMISSION

1. The transmission oil filter tube and dipstick must not be altered by bending, lengthening, or shortening, and must be readily accessible in the engine compartment for checking lubricant level.
2. Adequate tool clearance and suitable access openings for transmission adjustments must be provided. Transmission removal provisions must also be considered.
3. Transmission oil cooler lines should not be kinked, bent, or restricted. All oil cooler lines must be properly retained with adequate clips.
4. Vacuum throttle control line must not be bent, kinked, or restricted. Note: Vacuum-operated accessories must have separate engine vacuum source. Vacuum measurement must be within engine specifications.
5. Linkage and levers must not be altered and must have provision for adjusting tool clearance.
6. Transmission service identification tags must not be removed or destroyed. If the transmission is reworked or replaced, tag should be attached to new transmission.
7. Do not under any circumstances mount extra gauges, PTO controls, or throttle controls to the MD-Transmission Shift Control Tower. The Electronic Control Unit and the Vehicle Interface Module are mounted inside the shift tower and may become damaged when installing these added features.

MANUAL TRANSMISSION

1. If transmission shift rods are altered, the shift linkage geometry may be affected. Altered linkage is at the risk of the installer.
2. Transmission filler plug should not be obstructed, preventing easy checking of lube level or filling.

Freightliner Business Class M2

Cab and Chassis Vocational Reference Guide

General Information

REAR AXLE

1. The rear axle vent must not be obstructed in any way. The axle must be free to breathe. If it is not possible to keep the rear axle vent area unobstructed or, if there are environmental reasons for relocation of the vent, the vent system may be revised to provide for a frame-mounted remote vent.
2. Under no circumstances may any brackets or any other component be welded to the rear axle housing.

POWER TAKE-OFF INSTALLATIONS

1. On transmission-mounted power take-off installations, the engine-transmission maximum RPM must not exceed the power take-off manufacturer's recommended PTO maximum power and RPM rating. Power take-off output RPM must not exceed driveline and/or universal joint manufacturer's recommended maximum RPM and/or driveline angle specifications. It will be the equipment manufacturer's and/or installer's responsibility to properly design and install drivelines so the vehicle and component operation and durability is not adversely affected.
2. On crankshaft-driven power take-off installations, maximum take-off power and RPM must not exceed the engine manufacturer's maximum specifications (shown in the Transmission Section).

Caution: Heavy-duty power take-off applications operating for extended periods under stationary conditions may require additional shielding to prevent fuel vaporization and to protect various cables, hoses, tube assemblies and wiring assemblies from potentially higher exhaust manifold and pipe temperatures.

Truck Body and Special Equipment Installation Precautions

WHEELS AND TIRES

1. Use only wheels with the equivalent load capacity, rim width, rim offset, and mounting configuration as those originally installed on the vehicle. Consult an authorized Freightliner Truck dealer for correct wheel load capacity, size and usage. Wheels used must conform to FMVSS/ CMVSS-120.
2. Use only tires with the equivalent load-carrying capacity as those originally installed on the vehicle. Use only tires of a type and size that are recommended by the vehicle manufacturer and are compatible with the wheel installed on the vehicle. Do not over- or under-inflate tires; always maintain proper tire pressure. Never mix radial, bias-belted and/or conventional bias type tires, and avoid mixing P-metric tires with alphanumeric tires whenever possible.

Consult an authorized Freightliner Truck dealer for correct tire load capacity, type, size, and inflation pressure for the vehicle. Tires used must conform to FMVSS-119 (non-passenger car type tires) in the United States or to the Motor Vehicle Tire Safety Regulations in Canada.

3. Use of any other size or type wheel or tire other than those originally installed on the vehicle as manufactured by Freightliner may adversely affect load-carrying capacity, handling, bearing life, ride, and tire/ wheel clearance to the body and chassis components.

Freightliner Business Class M2

Cab and Chassis Vocational Reference Guide

General Information

STEERING

1. No alterations to the steering shaft(s) or steering column to steering gear alignment is permissible.
2. Steering gear, linkage, or column alteration or relocations are not permissible. Do not restrict steering linkage travel.
3. No vehicle/component alterations are allowed which may restrict or prevent steering wheel, column, or intermediate shaft collapse during crash.
4. Use of turn signals, etc., mounted on steering column must not affect steering column angles, steering column travel on adjustable columns or tilt/telescoping motion on tilt/telescoping columns.
5. Steering gear must be accessible for making steering gear mesh load and worm bearing preload checks and/or adjustments.
6. Steering column (and column-mounted shift linkages, where provided) installation procedures and torque specifications must conform to applicable shop manual practice.

COOLING

1. Radiators should not be used as a structural part or hold down for special bodies or equipment.
2. Radiator modification is not recommended.
3. Cooling inlet area should be free from blockages.
4. If damaged, fan must be replaced, never repaired or modified.
5. Shroud/finger guard must not be used as a load-carrying component.
6. Fan spacers and clutch assemblies should not be used as load-carrying components.

Note: Dimensions in parentheses are millimeters

Truck Body and Special Equipment Installation Precautions

ELECTRICAL

1. All wiring additions and revisions should comply with procedures described in the "Electrical Section" of this book.
2. All electrical connectors must be unplugged before doing any welding – this includes the batteries, engine, bulkhead connectors, ABS, etc.
2. If horns are relocated, location must be as high as possible with bell mouth of horn pointed downward.
3. If battery's locations are changed, new locations must be adequately ventilated, accessible for servicing, protected from road splash, and incorporate a shockless mounting.
4. If battery's locations are changed, requiring longer cables, heavier wire gauge battery cables must be used.
5. If the original equipment batteries are replaced by more than one battery or a battery of a larger capacity, the battery charging and power supply circuit must be checked and revised to carry the additional loads.
6. When lengthening wheelbase of vehicle with ABS, a new wiring harness must be ordered. Due to impedance of wiring, ABS will not work properly if wiring is cut and spliced.
7. Fog and driving lamps.

Note: State, provincial or local laws may regulate the manner in which the fog and driving lamps are used, or may require additional equipment for the particular use intended for the vehicle. It is the buyer's/owner's responsibility to determine the applicability of such laws to the buyer's/ owner's intended use for the vehicle and to arrange for the installation of required equipment.

SPEEDOMETER SYSTEM

1. Electronic modules requiring road speed signal should obtain a dual output sensor ensuring that the module has a high input impedance (greater than 12K OHMS).
2. Cutting or splicing of road speed signal circuits is not recommended.

Freightliner Business Class M2

Cab and Chassis Vocational Reference Guide

General Information

General

- Store vehicles in a dry, ventilated place; protect from sunlight if possible.
- If vehicles are stored outside, provide regular maintenance against rust and damage.

Body

- Wash vehicle thoroughly to remove dirt, grease, oil, tar, or mud from exterior surfaces, rear wheel housing, and underside of front fender.
- Periodically wash vehicles stored in exposed locations.
- Touch up exposed raw or primed metal to provide rust protection.
- Cover chrome and stainless steel parts with a thick coat of auto wax to prevent discoloration. Rewax as necessary when the vehicle is washed.
- Lubricate all hood, door hinges and latches with a light grade oil. Caution: Keep all rubber parts free from oil and solvents.
- Cover the interior soft trim to prevent fading, if stored in exposed location.

Engine

- Start the engine every 15 days and move the vehicle at least 25 feet. Run it at fast idle until it reaches normal operating temperature.
- Shift the transmission into all gears while engine is running.

Fuel System

Diesel fuel deterioration in the form of fuel separation, sludge formation, and bacterial growth can cause restrictions in fuel supply lines, filters and sticking of fuel injection system components.

- Add a diesel fuel stabilizer ("Fire Prep 100" or equivalent) to diesel-powered vehicles whenever actual or expected storage periods exceed 60 days. The manufacturer's instructions packaged with product should be followed.

Truck Body and Special Equipment Installation Precautions

- The vehicles should then be operated at an idle speed to circulate the additive throughout the fuel system.

Cooling System

- Maintain appropriate antifreeze protection against freezing temperatures.

Battery

- Check and recharge as necessary.
- Keep connections clean and covered with light coat of grease.

Brakes

- Make sure brakes and the parking brake fully release.

Tires

- Maintain recommended air pressures.

Miscellaneous

- Verify that all linkages, cables, clevis pins, and levers under the vehicle are covered with grease to prevent rust.
- Move trucks at least 25 feet every 15 days to lubricate working parts and prevent corrosion.

Transmission

- Run engine to normal operating temperature.
- Shift the transmission into all gears with engine running.
- Check fluid level and condition (no water contamination, etc.).
- Basic (Stripped) Chassis Vehicles -cover transmission to prevent water from entering through the vent.

Freightliner Business Class M2 Cab and Chassis Vocational Reference Guide

General Information

Correct body mounting is critical to maintaining vehicle handling characteristics and the service life of the body and truck chassis.

Selection of the body mounting method should be based on the type of body being installed, chassis type, and vehicle applications.

Two common methods of attaching bodies to the chassis are discussed on the following pages. In each method, the general advantages of using that particular method are also discussed. This can help the installer decide which method of attachment is best for a given situation. Also included are guidelines that should be followed by the Final Stage Manufacturer when using a particular method of attachment.

U-bolts or bracket connections are not to be located in the vicinity of the rear axle or suspension.

The U-bolts should not contact the frame sidemember. Do not notch frame side-rail-flanges in order to "force" a U-bolt fit as shown in FIGURE 1. If the side-rail flanges are too wide, obtain a larger U-bolt or use another method of attachment.

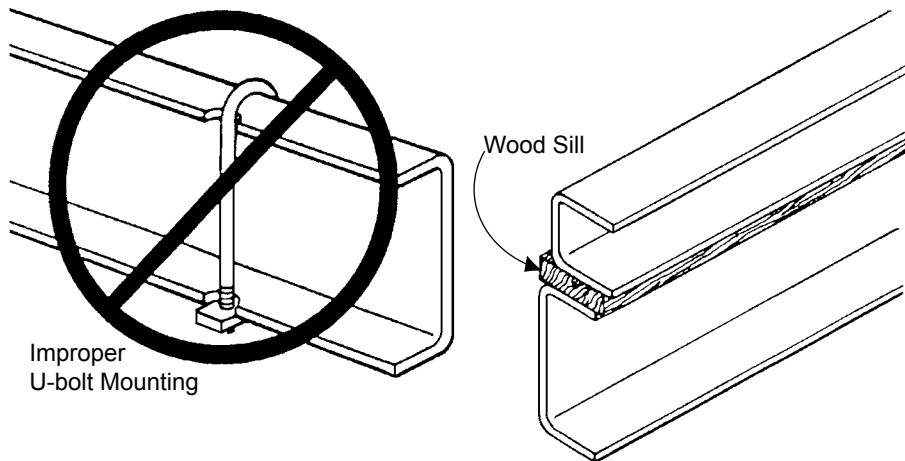

FIGURE 1 U-bolt on notched side rail can cause premature failure of frame rail

FIGURE 2 Wood Sill installed between body mounting frame and upper frame flange

Note: Dimensions in parentheses are millimeters

Body Mounting Methods

A mounting sill of hardwood or other suitable material may be installed between the body mounting frame and upper frame flange to protect the top surface of the frame flange (FIGURE 2) and allow for irregularities in the surfaces of the two members.

Some chassis frame assemblies use a partial frame length L-reinforcement (FIGURE 3). It is suggested to add a .25 inch spacer, or modify the wood sill to compensate for the L-reinforcement.

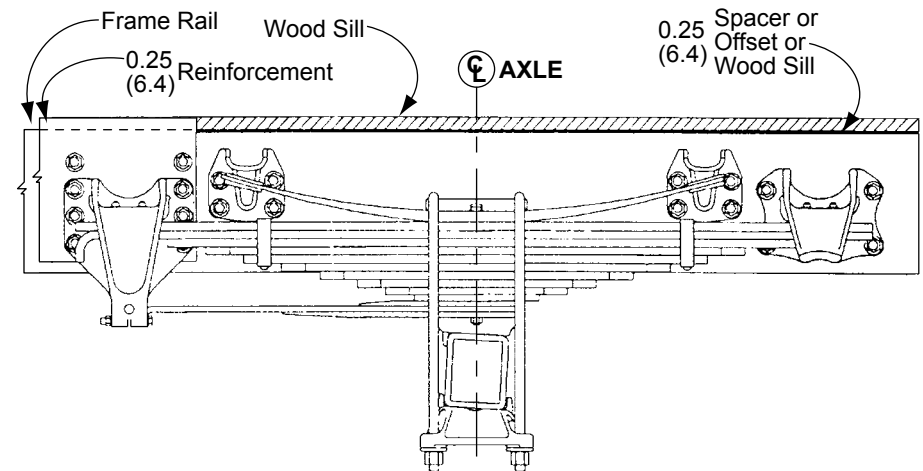

FIGURE 3 Frame rail with 1/4" Outsert

Freightliner Business Class M2 Cab and Chassis Vocational Reference Guide

General Information

BOLTED ATTACHMENT METHOD

Bolted attachment methods include clips, brackets, and other mountings bolted to the non-critical areas of the web of the frame rail. The use of existing factory drilled holes in the frame web is encouraged. If in doubt as to areas of hole drilling, contact your nearest Regional Service Manager.

Two basic bolted types of attachment are rigid mount (FIGURES 4 & 5) and flexible mount (FIGURES 6 & 7). The flexible mount system allows subframe movement. Torsionally stiff bodies such as refuse and tank type bodies utilize this type of mounting. They should be mounted to allow some flexing of the truck frame under normal driving conditions. Flexible mounting can be accomplished by using rubber mountings, spring loaded brackets, or similar types of attachment.

The proper size and grade of fasteners are mandatory. It is recommended that SAE grade 8 bolt fasteners with self-locking nuts be used for all 3/8" and larger. Hardened flat washers or flange head nuts and bolts should be used on both sides. Fasteners should be properly torqued.

Body Mounting Methods

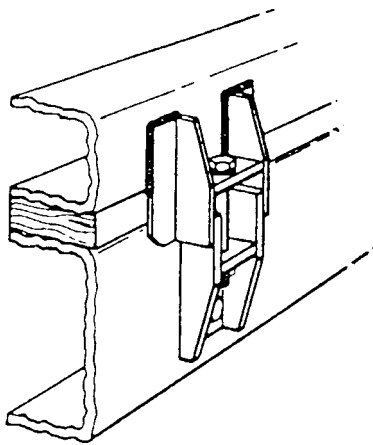

FIGURE 4 Rigid Mount

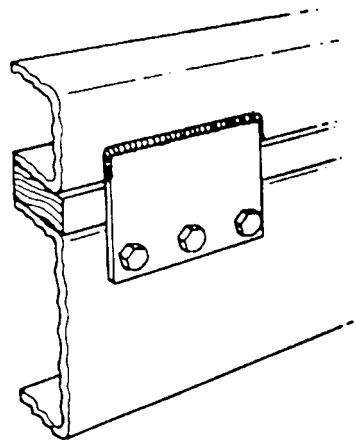

FIGURE 5 Rigid Mount

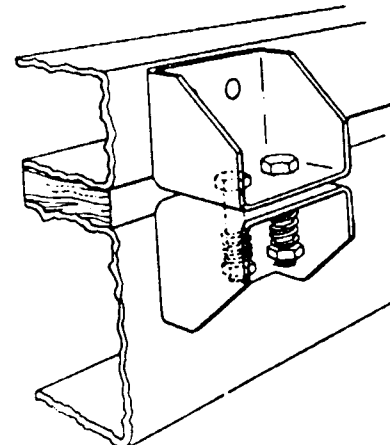

FIGURE 6 Spring loaded attachment

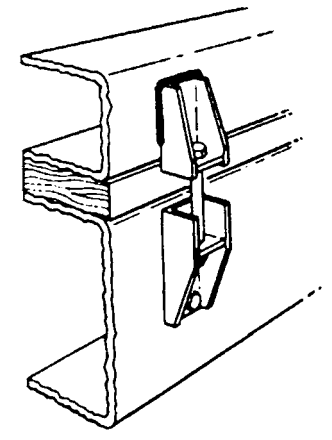

FIGURE 7 Attachment clamp, allowing longitudinal movement

Freightliner Business Class M2 Cab and Chassis Vocational Reference Guide

General Information

U-BOLT AND CLAMP ATTACHMENT

U-bolts and clamping devices (FIGURE 8) are readily accepted methods of mounting torsionally resilient bodies such as vans and platform bodies. These methods are the least time consuming and least expensive methods of mounting (FIGURE 9).

Both methods avoid modifications to the frame such as drilling.

When using U-bolts, it is mandatory that a spacer be installed on the inside of the frame rail to prevent collapse of the frame flanges as the U-bolts are tightened. The spacer should be fabricated of either steel or hardwood. Steel is preferable due to the possibility of the wood shrinking and falling out.

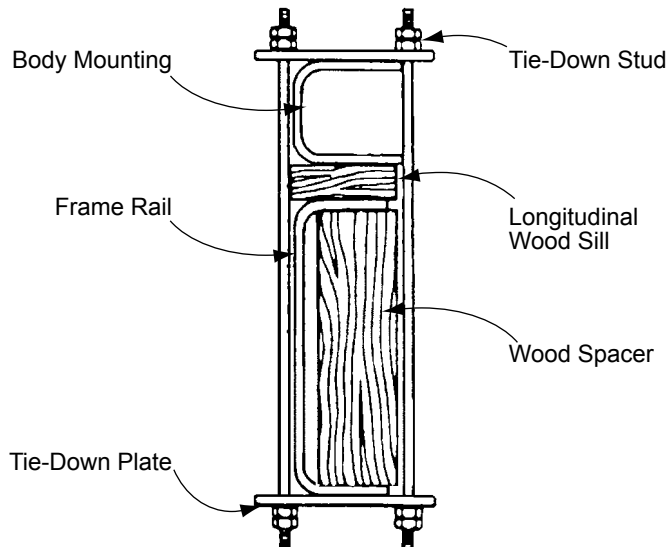

FIGURE 8 Typical attachment with hardwood spacer

Note: Dimensions in parentheses are millimeters

Body Mounting Methods

The spacers should be positioned to provide adequate support for the frame flanges and not interfere with any plumbing or wiring routed along the frame rails.

Since U-bolts and clamping devices rely on friction and a maintained clamping force for attachment, the area must be free of oils, grease and other agents which would possibly hamper the attachment allowing slippage.

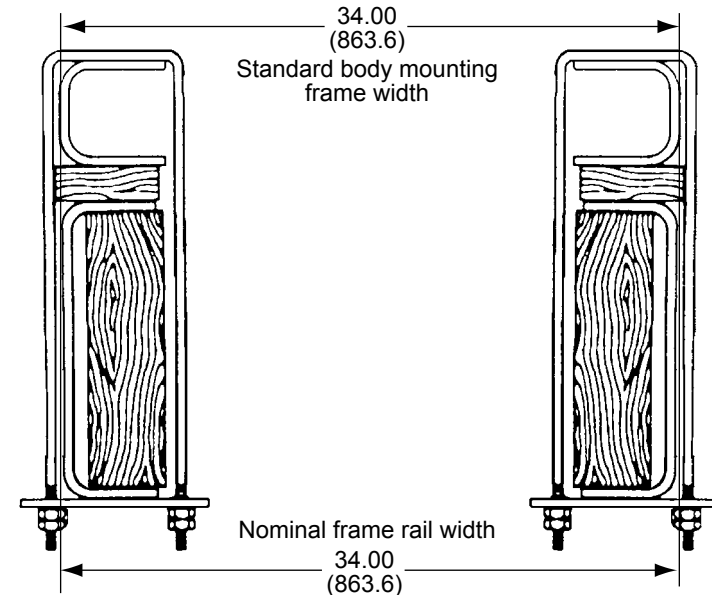
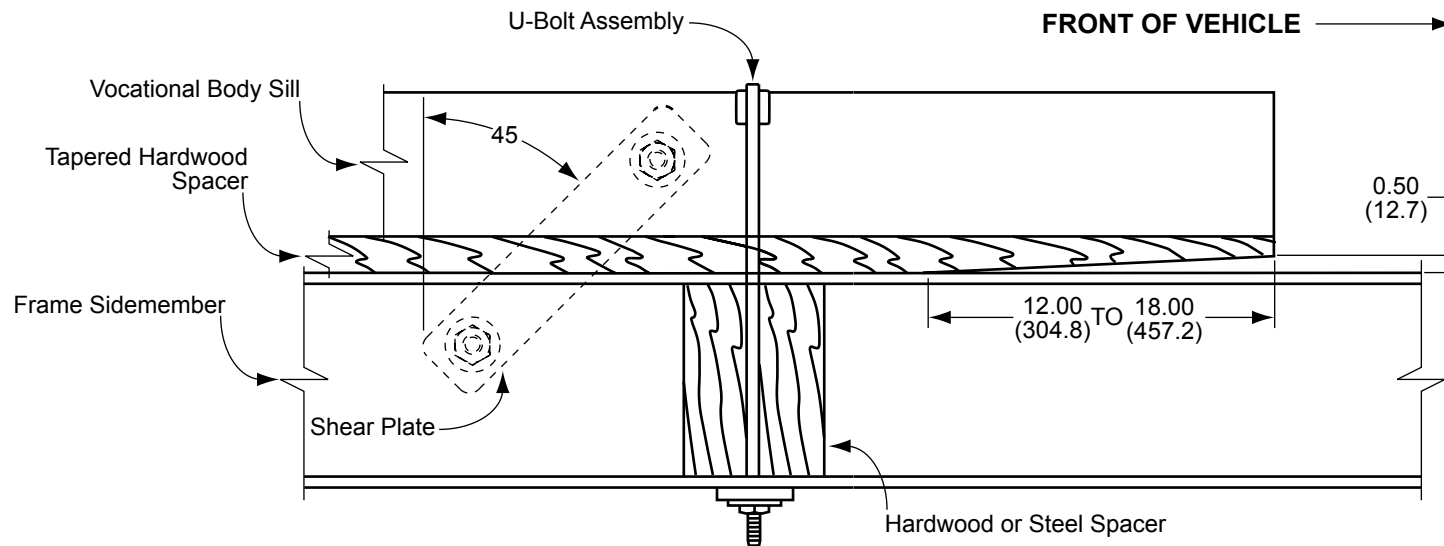

FIGURE 9 Frame rail and body mounting frame widths

Freightliner Business Class M2 Cab and Chassis Vocational Reference Guide

General Information



Vocational Body Mounting

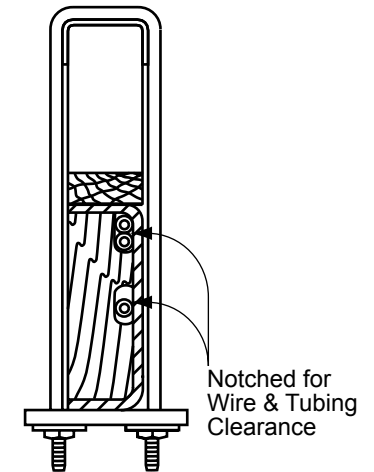

Typical Installation (View showing inboard side of rail)

- Where wraparound body attachments (such as U-bolts) are used, the frame side-members must have flange reinforcement spacers to avoid flange damage when full torque is applied to attaching bolts. Hardwood spacers are recommended and must be cut out to clear brake lines, fuel lines, wiring, etc. If metal spacers are used, no welding to sidemembers is permitted.
- Tapered hardwood spacers between vocational-body sill and frame sidemember flanges are required. Recommended taper is 1/2" at the front end diminishing to contact 12" to 18" rearward (see sketch for typical installations).
- The first body attachment should not be forward of where the taper meets the sidemember.
- A minimum of three (3) body attachments per side is recommended.
- Periodic checking of body attachments for torque retention is highly recommended.
- A minimum of one set of shear plates per side is recommended.
- A minimum of three (3) body attachments per side is recommended.
- Periodic checking of body attachments for torque retention is highly recommended.
- A minimum of one set of shear plates per side is recommended.